

Gril Vertical mod **GV2**

Dimensiones:

582 mm (l) x 1540 mm (a) x 1264 mm (p)

N.º grilles: 2

Capacité/poulet: 6

Poids: 153 kg

Puissance nominale (consommation / heure): 7,8 kw

Tension Nominale	Courante Nominale
400V 3N~	11A (L1) 11A (L2) 11A (L3)
220V 3~	22A (L1) 22A (L2) 22A (L3)
222V 1N~	35A (L1)



GRE.V1.E40
grattoir



GRE.V1.J10
grille XS (8 mm)



GRE.V1.J40
grille S (19 mm)



GRE.V1.J30
grille XL (31 mm)



GRE.V1.S10
système de
drainage

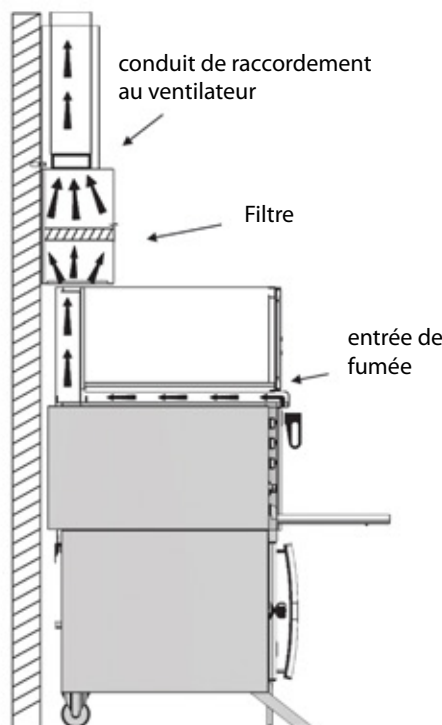

GRE.CA.A50
gouttière



GRE.V2.P10
Module avec filtre



GRE.V2.P30
Conduite

Remarque: avec dispositif de connexion à l'entrée et à la sortie d'eau pour la boîte à graisse

Gril Vertical mod **GV2**

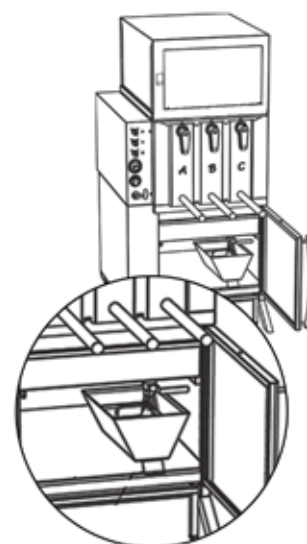
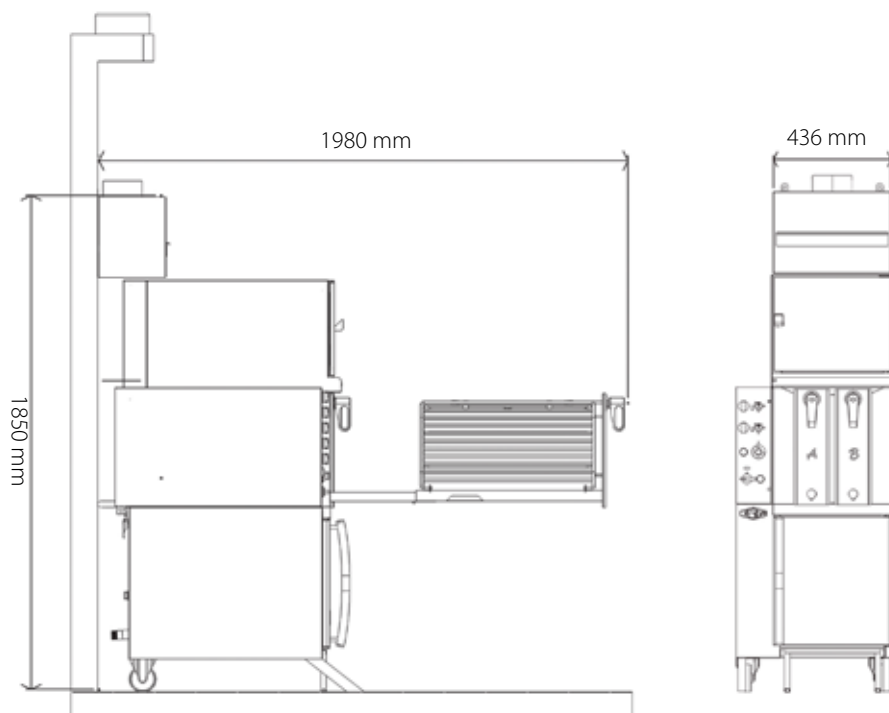
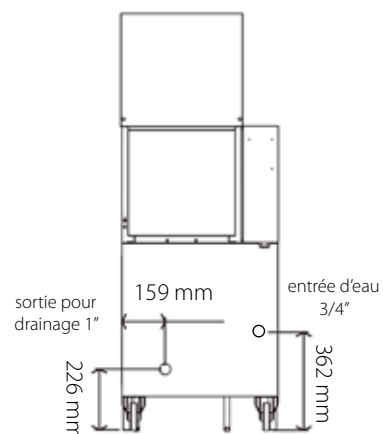
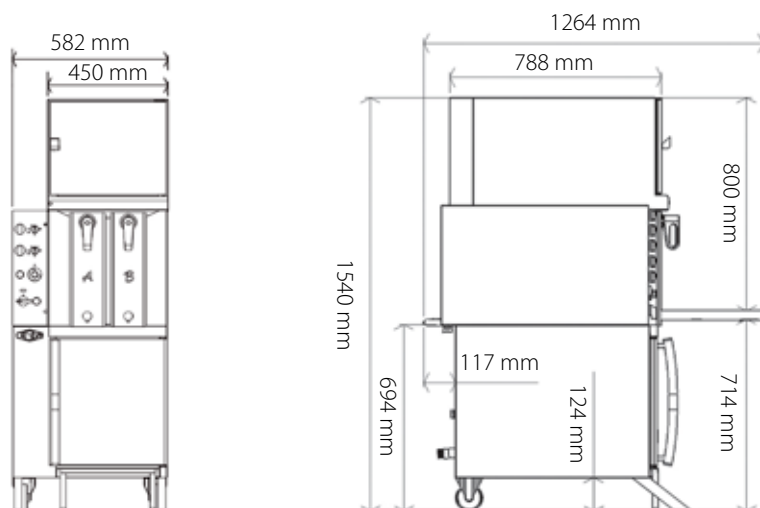

Un système d'écoulement constitué d'un conteneur de collecte d'eau à partir du tiroir récepteur à connecter à la boîte de graisses